

■Features

- Top view white LED (3.0 x 1.4 x 0.8mm)
- Super high brightness of surface mount LED
- Lead frame package with individual 2 pins
- Compatible to IR reflow soldering.

■Applications

- General lighting
- Decoration lighting
- Indicator

■Outline Dimension

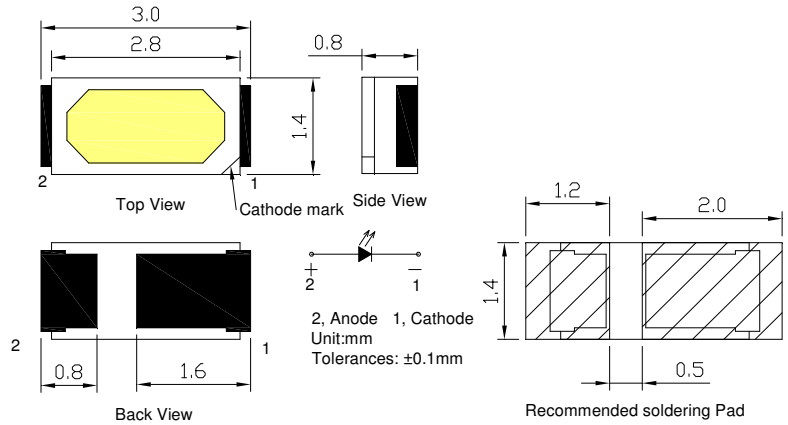

■Absolute Maximum Rating

(Ta=25°C)

| Item | Symbol | Value | Unit |
|----------------------------|-----------|------------|------|
| DC Forward Current | I_F | 30 | mA |
| Pulse Forward Current* | I_{FP} | 100 | mA |
| Reverse Voltage | V_R | 5 | V |
| Power Dissipation | P_D | 110 | mW |
| Operating Temperature | T_{opr} | -40 ~ +85 | °C |
| Storage Temperature | T_{stg} | -40 ~ +85 | °C |
| Lead Soldering Temperature | T_{sol} | 260°C/5sec | - |

*Pulse width Max 0.1ms, Duty ratio max 1/10

■Directivity

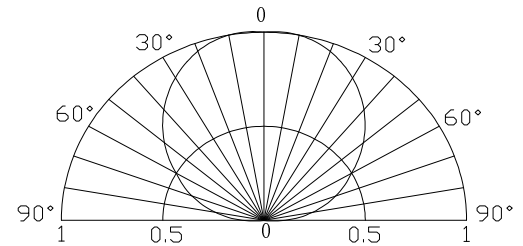

■Electrical -Optical Characteristics

(Ta=25°C)

| Part Number | Color | | V_F (V) | | | I_R (μ A) | I_v (mcd) | | | CCT | | | 2 θ 1/2(deg) |
|-------------|------------|---|-------------|------|------|------------------|-------------|------|------|-------|------|-------|---------------------|
| | | | Min. | Typ. | Max. | Max. | Min. | Typ. | Max. | Min. | Typ. | Max. | Typ. |
| | | | $I_F=20$ mA | | | $V_R=5$ V | $I_F=20$ mA | | | | | | |
| OSW33014C1A | White | W | 2.9 | 3.1 | 3.6 | 10 | 2000 | - | 3000 | 5000K | - | 6000K | 120 |
| OSM53014C1A | Warm White | M | 2.9 | 3.1 | 3.6 | 10 | 2000 | - | 3000 | 2800K | - | 3500K | 120 |

Note: * V_f tolerance: ± 0.05 V

* Luminous flux measurement allowance is: $\pm 10\%$

■ Rank

* Correspondence Table of Luminous Flux – Intensity

| Rank | Luminous Intensity (mcd) | Luminous Flux (lm)* |
|------|--------------------------|---------------------|
| T11 | 2000~2150 | 5.9~6.3 |
| T12 | 2150~2300 | 6.3~6.8 |
| T21 | 2300~2450 | 6.8~7.2 |
| T22 | 2450~2600 | 7.2~7.6 |
| U11 | 2600~2800 | 7.6~8.2 |
| U12 | 2800~3000 | 8.2~8.8 |

*Luminous flux measurement allowance is ±10% (for reference)

■ Chromaticity Diagram

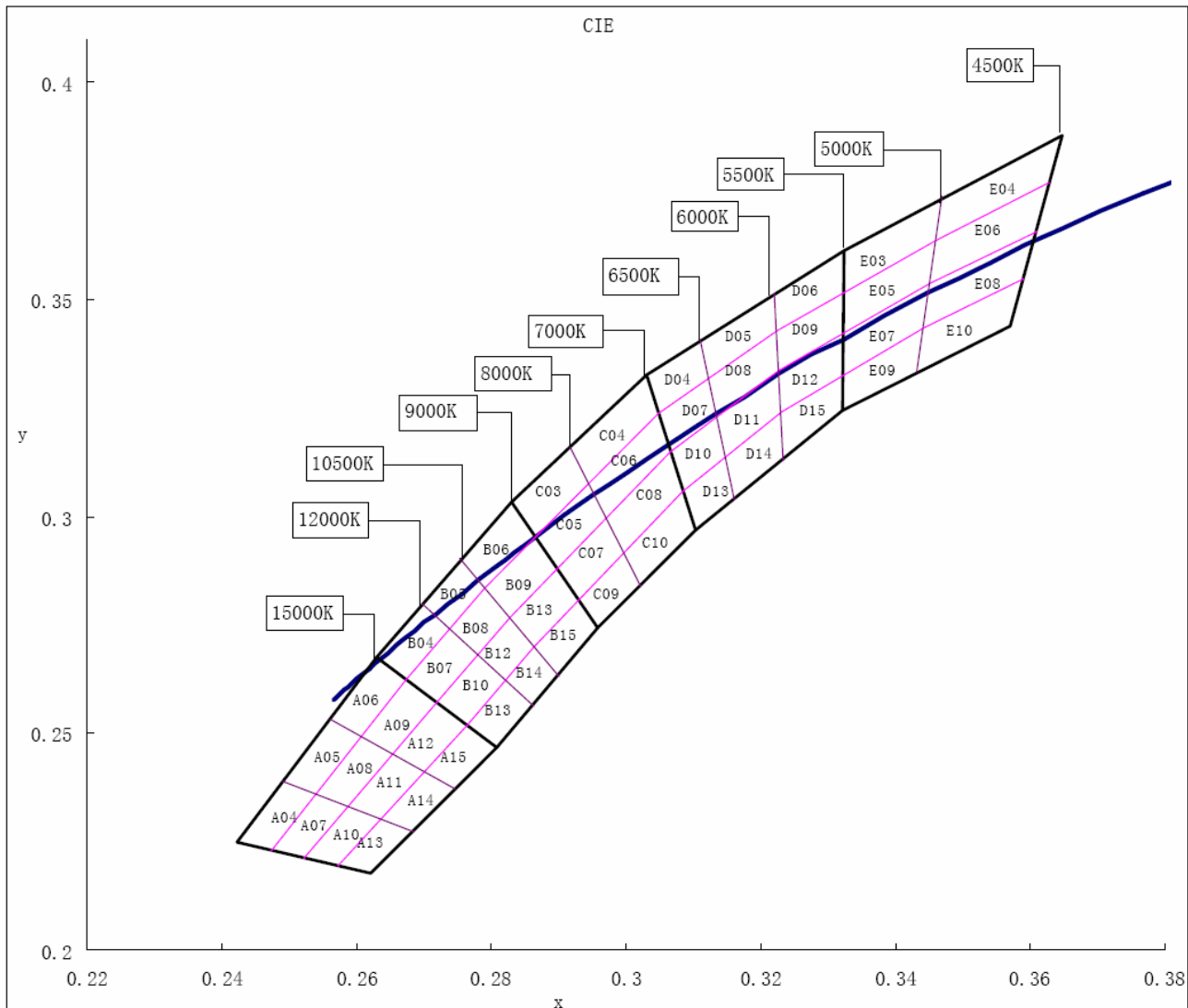

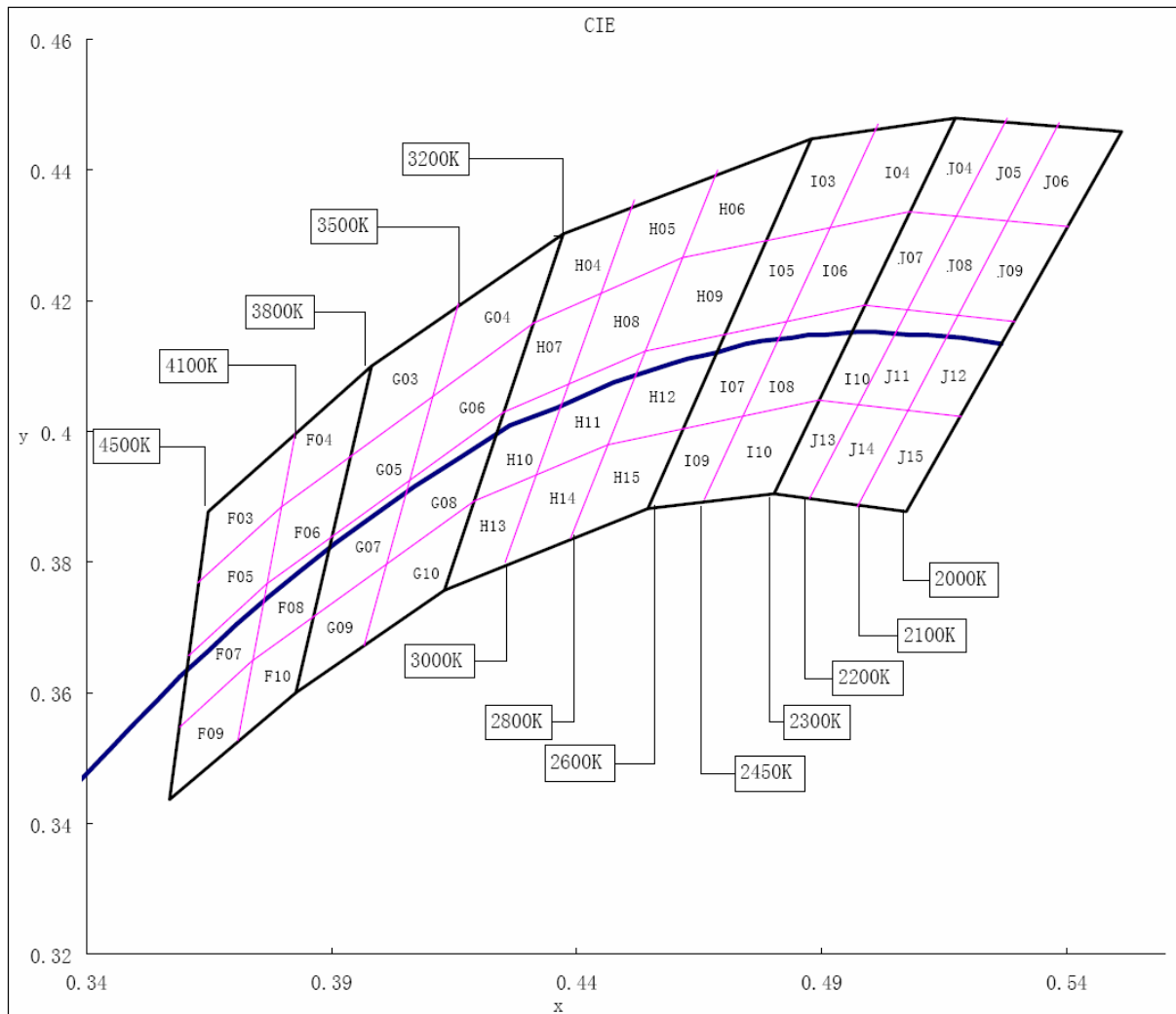

***Bin Range of Chromaticity Coordinates (OSW33014C1A)**

| Code | X1 | Y1 | X2 | Y2 | X3 | Y3 | X4 | Y4 |
|------|--------|--------|--------|--------|--------|--------|--------|--------|
| D06 | 0.3221 | 0.3523 | 0.3324 | 0.3612 | 0.3324 | 0.3520 | 0.3224 | 0.3420 |
| D09 | 0.3224 | 0.3430 | 0.3324 | 0.3520 | 0.3323 | 0.3429 | 0.3228 | 0.3336 |
| D12 | 0.3228 | 0.3336 | 0.3323 | 0.3429 | 0.3323 | 0.3337 | 0.3231 | 0.3243 |
| D15 | 0.3231 | 0.3243 | 0.3323 | 0.3337 | 0.3322 | 0.3245 | 0.3234 | 0.3149 |
| E03 | 0.3324 | 0.3612 | 0.3470 | 0.3738 | 0.3461 | 0.3637 | 0.3324 | 0.3520 |
| E05 | 0.3324 | 0.3520 | 0.3461 | 0.3637 | 0.3452 | 0.3536 | 0.3323 | 0.3429 |
| E07 | 0.3323 | 0.3429 | 0.3452 | 0.3536 | 0.3442 | 0.3435 | 0.3323 | 0.3337 |
| E09 | 0.3323 | 0.3337 | 0.3442 | 0.3435 | 0.3433 | 0.3334 | 0.3322 | 0.3245 |

***Bin Range of Chromaticity Coordinates (OSM53014C1A)**

| Code | X1 | Y1 | X2 | Y2 | X3 | Y3 | X4 | Y4 |
|------|--------|--------|--------|--------|--------|--------|--------|--------|
| G04 | 0.4160 | 0.4199 | 0.4373 | 0.4302 | 0.4313 | 0.4166 | 0.4112 | 0.4067 |
| G06 | 0.4112 | 0.4067 | 0.4313 | 0.4166 | 0.4252 | 0.4030 | 0.4063 | 0.3936 |
| G08 | 0.4063 | 0.3936 | 0.4252 | 0.4030 | 0.4192 | 0.3893 | 0.4015 | 0.3804 |
| G10 | 0.4015 | 0.3804 | 0.4192 | 0.3893 | 0.4131 | 0.3757 | 0.3966 | 0.3672 |
| H04 | 0.4373 | 0.4302 | 0.4518 | 0.4354 | 0.4453 | 0.4216 | 0.4313 | 0.4166 |
| H05 | 0.4518 | 0.4354 | 0.4689 | 0.4408 | 0.4614 | 0.4265 | 0.4453 | 0.4216 |
| H07 | 0.4313 | 0.4166 | 0.4453 | 0.4216 | 0.4387 | 0.4077 | 0.4252 | 0.4030 |
| H08 | 0.4453 | 0.4216 | 0.4614 | 0.4265 | 0.4539 | 0.4123 | 0.4387 | 0.4077 |
| H10 | 0.4252 | 0.4030 | 0.4387 | 0.4077 | 0.4322 | 0.3939 | 0.4192 | 0.3893 |
| H11 | 0.4387 | 0.4077 | 0.4539 | 0.4123 | 0.4463 | 0.3980 | 0.4322 | 0.3939 |
| H13 | 0.4192 | 0.3893 | 0.4322 | 0.3939 | 0.4256 | 0.3800 | 0.4131 | 0.3757 |
| H14 | 0.4322 | 0.3939 | 0.4463 | 0.3980 | 0.4388 | 0.3837 | 0.4256 | 0.3800 |

*If color binning is required, only one color group is allowed for each chip within a reel.

Chromaticity coordinate groups are measured with an accuracy of ± 0.01

*Color coordinate is derived from the CIE 1931 chromaticity.

***Bin rank of VF**

| Rank ($I_F=20mA$) | White | | |
|-----------------------|---------|---------|---------|
| | 88T-999 | AAA | BBB |
| DC Forward Voltage(v) | 2.9-3.2 | 3.2-3.4 | 3.4-3.6 |

*Forward voltage is measured with an accuracy of $\pm 0.1V$.

■ Typical Electro-Optical Characteristics Curves

Spectrum

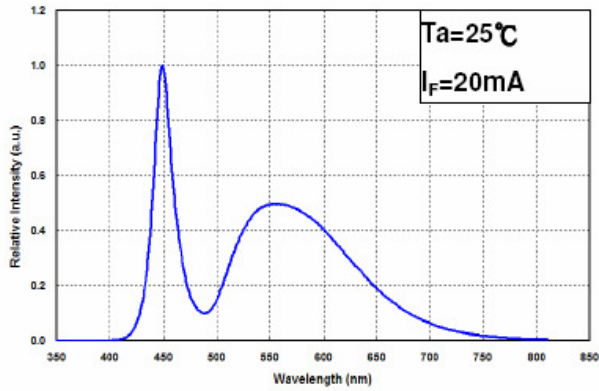

Luminous Intensity — I_F

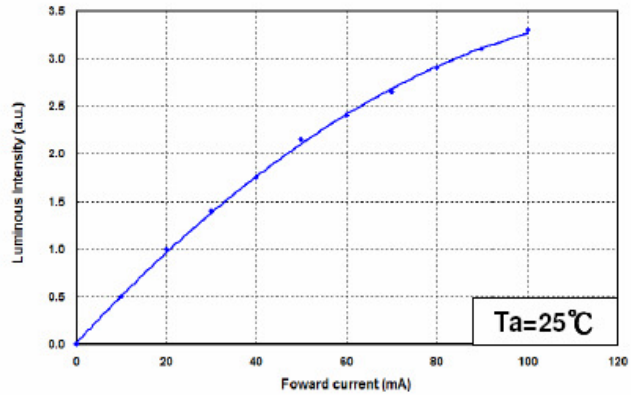

$I_F - V_F$

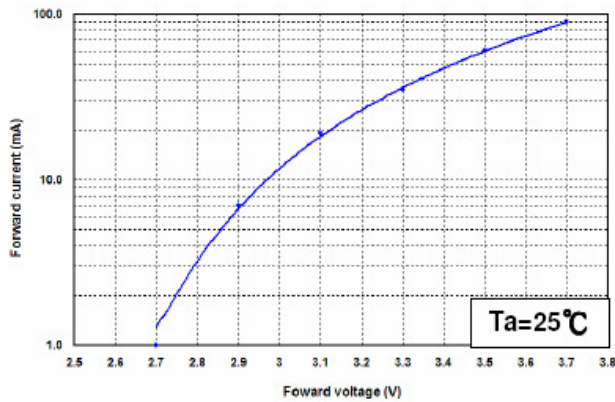

$I_F - T_a$

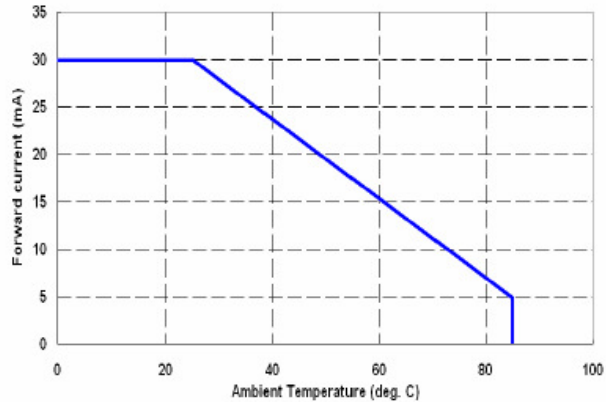

Radiation Pattern

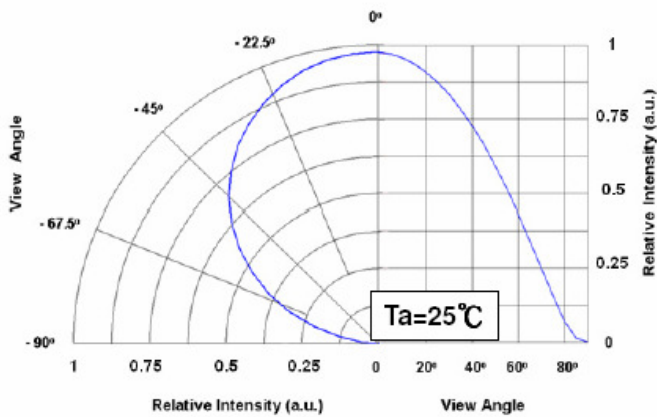

RELIABILITY TEST REPORT

| CLASSIFICATION | TEST TIME | TEST CONDITON |
|--------------------|--|--|
| ENDURANCE TEST | OPERATION LIFE | If:20mA Ta:25+5 TEST ITME=1000HRS(-24HRS,+72HRS) |
| | HIGH TEMPERTURE HIGH HUMIDITY STORAGE | R.H:90~95% Ta:65+5°C TEST ITME=240HRS(+2HRS) |
| | HIGH TEMPERTURE STORAGE | Ta:105±5°C TEST ITME=500HRS(-24HRS,+48HRS) |
| | LOW TEMPERTURE STORAGE | Ta:-55±5°C TEST ITME=500HRS(-24HRS,+48HRS) |
| ENVIRONMENTAL TEST | TEMPERTURE CYCLING | 105°C~25°C~-55°C~25°C 60min 10min 60min 10min 20cycles |
| | THERMAL SHOCK | 105°C~-55°C 10min 10min 10cycles |
| | SOLDER RESISTANCE | Ta:260±5°C TEST ITME=10±1sec |
| | SOLDERABILITY | Ta:230±5°C TEST ITME=5±1sec |

JUDGMENT CRITERIA OF FALURE FOR THE RELIABILITY

| MEASURING ITME | SYMBOL | CONDITIONS | FAILUER |
|--------------------|--------|------------|-------------------------|
| LUMINOUS INTENSITY | IV | IF=20mA | IV<0.5*INITIAL VALUE |
| FORWARD VOLTAGE | VF | IF=20mA | VF>1.2*INITIAL VALUE |
| REVERSE CURRENT | IR | Vr=5V | IR>2*SPEC |

■ Recommended Reflow Soldering Profile

Surface mounting condition

In automatic mounting of the SMD LEDs on printed circuit boards, any bending, expanding and pulling forces or shock against the SMD LEDs should be kept min. to prevent them from electrical failures and mechanical damages of the devices.

Soldering reflow

- Soldering of the SMD LEDs should conform to the soldering condition in the individual specifications.
- SMD LEDs are designed for reflow soldering.
- In the reflow soldering, too high temperature and too large temperature gradient such as rapid heating/cooling may cause electrical & optical failures and damages of the devices.
- Wellypower can't guarantee the LEDs after they have been assembled using the solder dipping method.

1) Lead solder

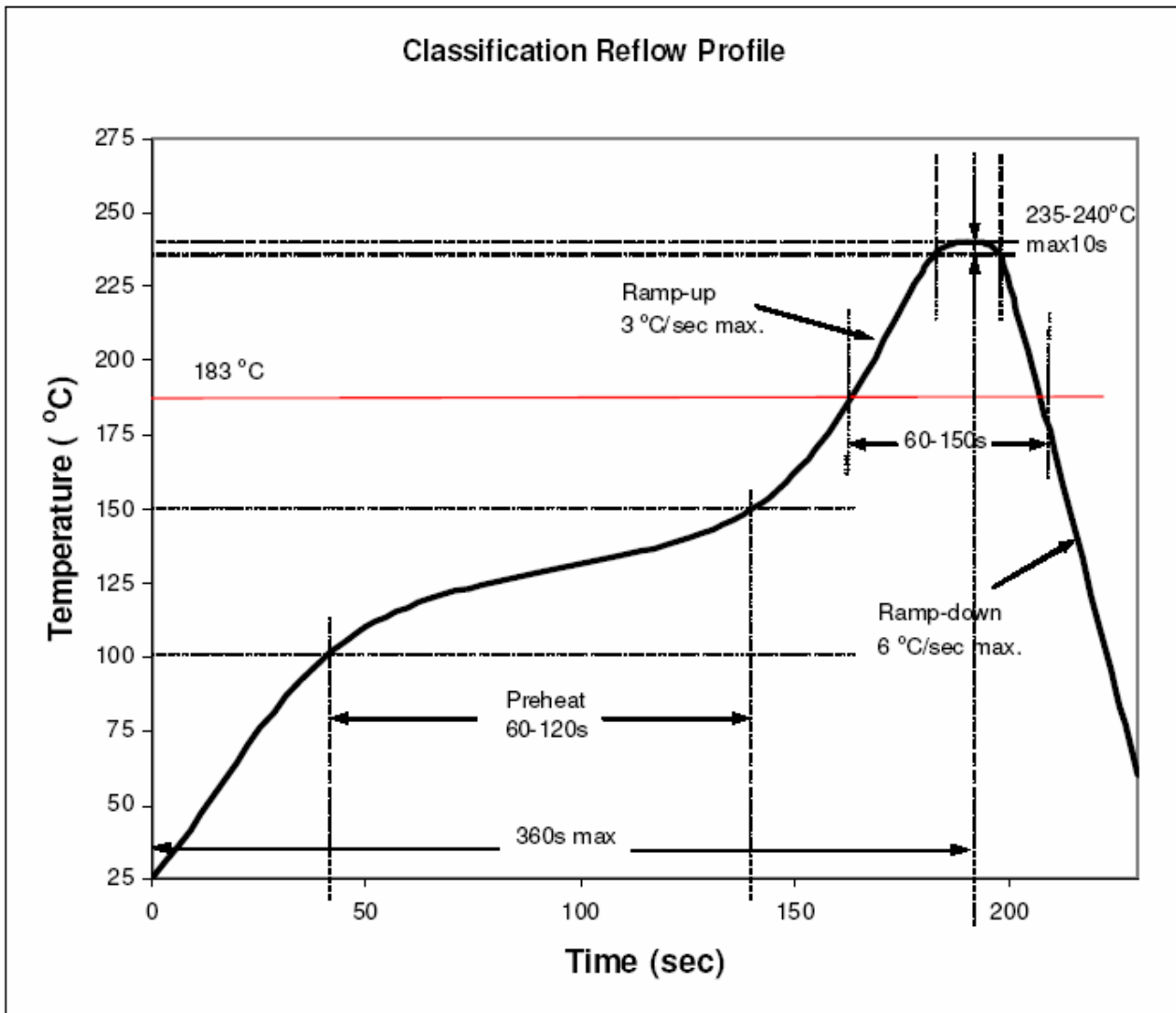

2) Lead-free solder

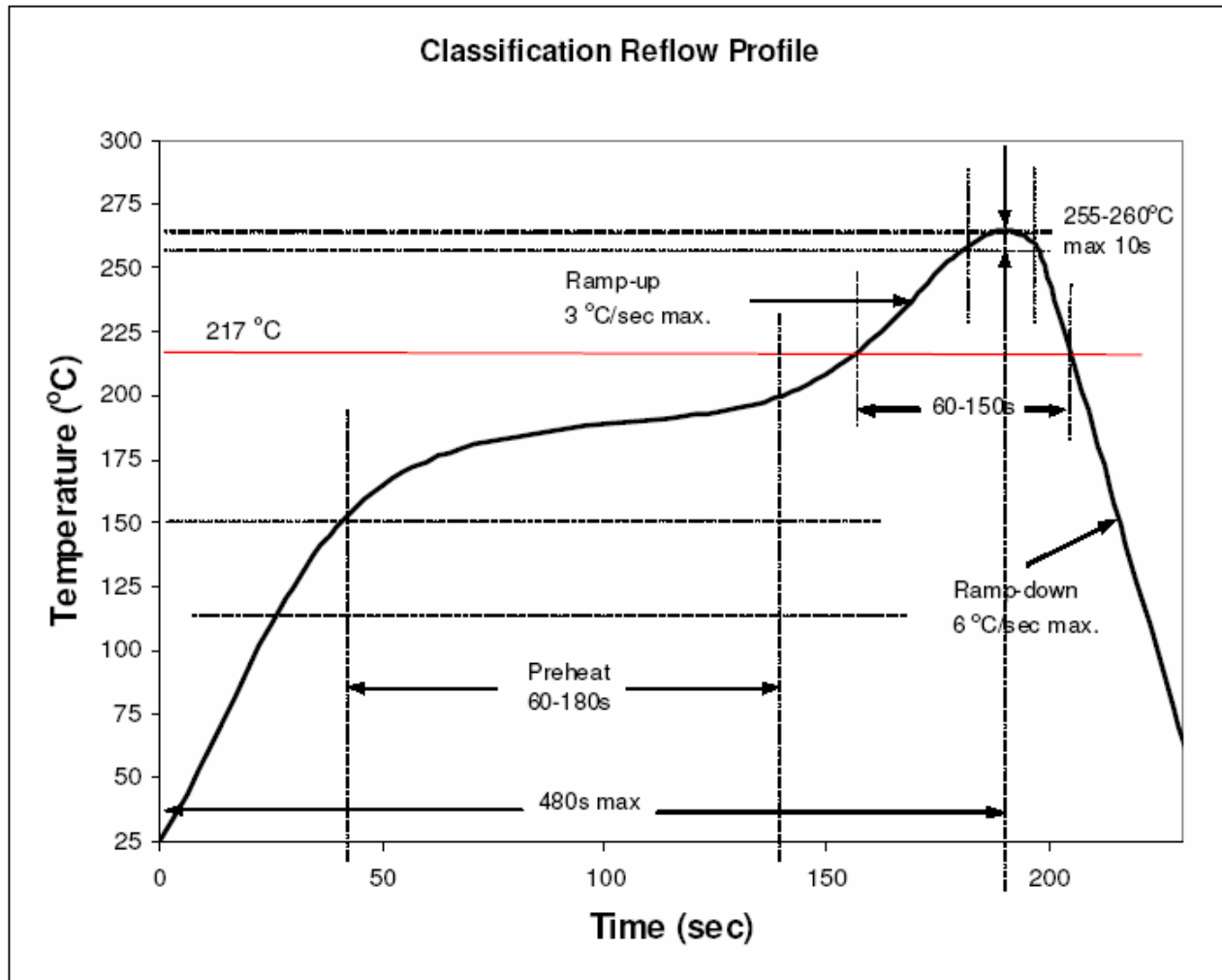

3) Manual soldering.

- Lead solder

Max. 300°C for max. 3sec, and only one time.

- Lead-free solder

Max. 350°C for max. 3sec, and only one time.

- There is possibility that the brightness of LEDs is decreased, which is influenced by heat or ambient atmosphere during reflow. It is recommended to use the nitrogen reflow method use the nitrogen reflow method.

- After LEDs have been soldered, repairs should not be done. As repair is unavoidable, a doublehead soldering iron should be used. It should be confirmed beforehand whether the characteristics of the LEDs will be damaged by repairing or not.

- Reflow soldering should not be done more than two times.

■ Package Model

Loaded Quantity 4000 pcs. Per Reel

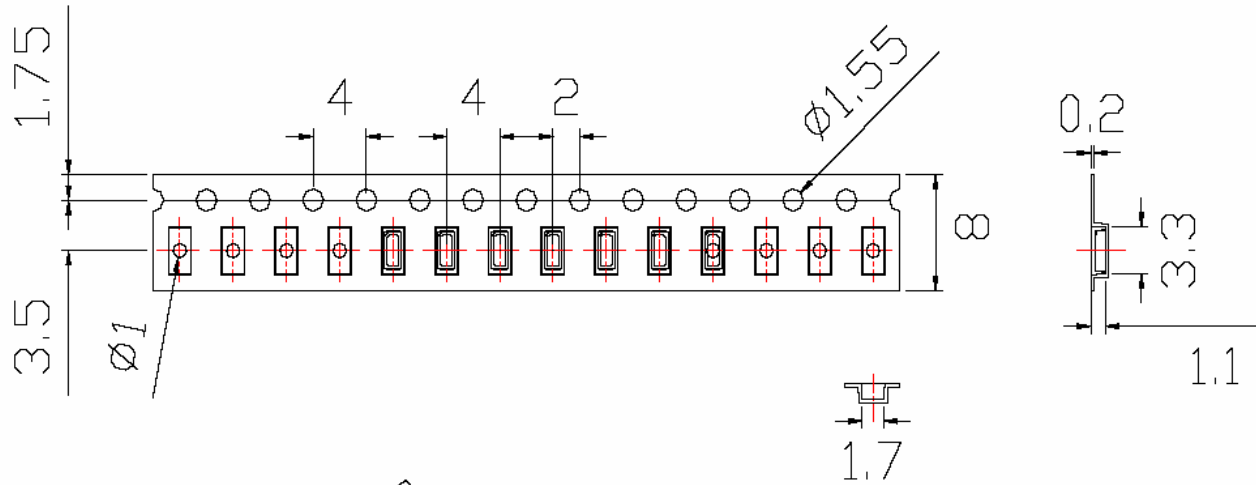

Reel Part

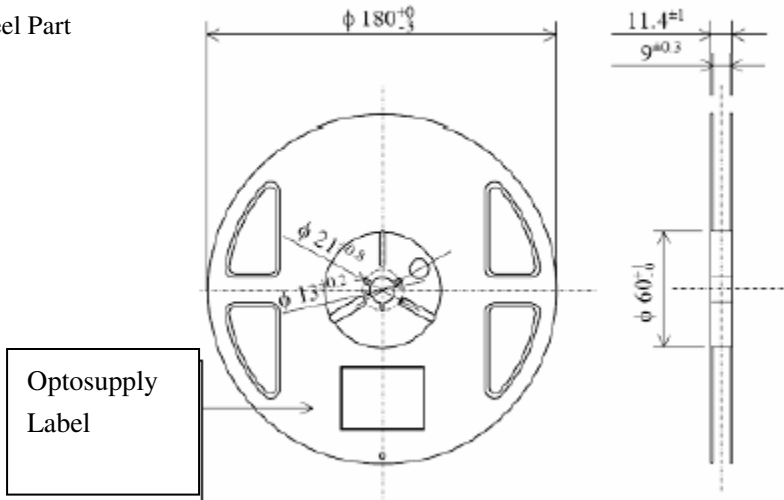

Optosupply
Label